

CM85 vacuum generator

operating instructions

1. Positive pressure of 0.5Mpa, ± 0.05 Mpa is applied to both sides of the P at the same time, and there are 1 minute 8mm-10mm trachea on both sides.
2. V is the vacuum port, which is connected to an external M5 connector and a 4/6mm air pipe. In order to ensure a longer service life, an air filter core needs to be connected between the V port and the suction cup to prevent dust and debris from being sucked into the vacuum and affecting the service life of the vacuum valve.
3. VAC is a vacuum switch control valve, DC/24V.
4. BLOW is a vacuum breaking control valve, DC/24V.
5. The slotted screw is used to adjust the size of the vacuum break. Clockwise is to adjust the size of the vacuum, and counterclockwise is to adjust the size of the vacuum.
6. Digital display pressure switch wiring method:
Brown is the power input DC/24V
Blank is NPN output
White is an analog signal output 1-5V
Blue is OV

Digital pressure switch wiring diagram

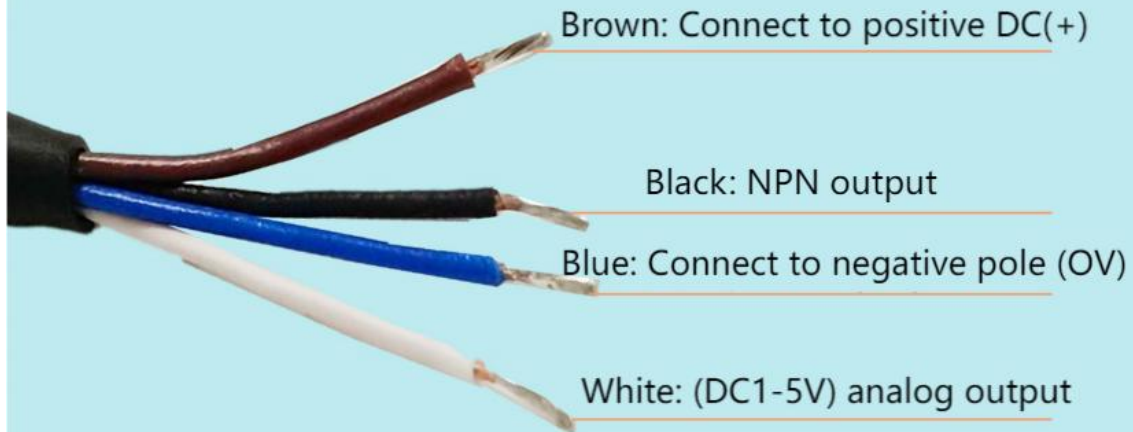

Brown is connected to the power supply +24V, blue is connected to Ov, black is connected to the Npn signal output, and white is the 1-5V analog output. 3-5V represents positive pressure 0/100Kpa, 3-IV represents negative pressure 0-minus 100Kpa.

Digital display switch parameter setting operating instructions



Press the Up key to select the parameter directory to be adjusted for P1, P2, and Np. After selecting the directory, press the Down key to enter the corresponding parameter setting. Press Up/Down again to adjust the parameter value. After adjustment, it will flash for three seconds and automatically save and exit the setting.

Digital display switch parameter setting operating instructions



P1

The P1 setting value represents the reached value, for example, set to -60. When the vacuum rises to -60 or above, the Npn signal is output



P2

The P2 setting value represents the recovery value, for example, set to -55. When the vacuum value drops from a high value to -55 or below, the Npn signal recovers. There is no need to wait until the vacuum value drops to 0 before the signal is restored.

Note: The P2 setting value can only be set below P1.

The P2 setting value cannot be lower than the initial value when the component is not picked up after the vacuum is turned on, otherwise the signal will be a true output and cannot be restored!



Np



Noo



Noc

Energy-saving PNP output

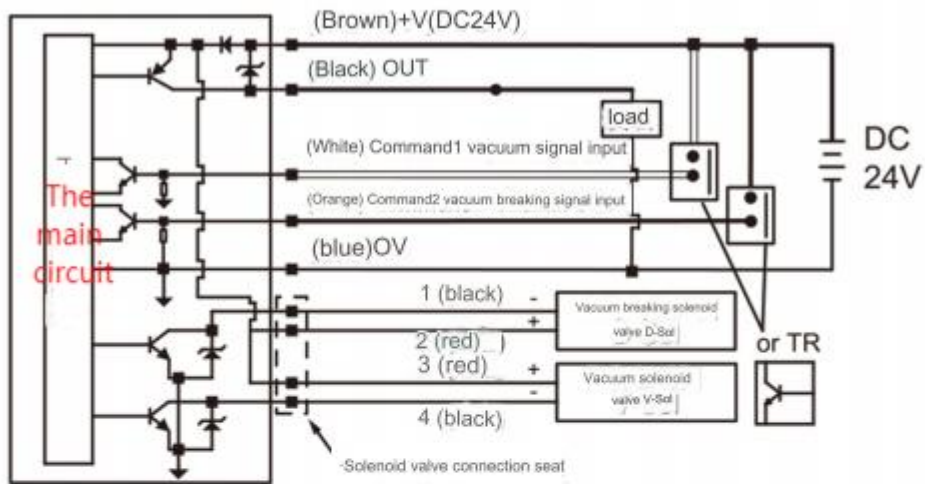

V9-NPN output

